

ABLOY® KEY DEPOSITS



ABLOY® key deposits are used for storing route keys to apartment complexes, office buildings and factories.

ABLOY® key deposits for storing route keys

Construction

Key deposit housing	Steel
Cylinder housing	Hardened steel
Cylinder plug	Brass
Discs and washers	Tin bronze
Number of discs	11

Finish

Key deposit housing	Zinc plated
Cylinder housing	Satin chrome

Cylinder types available

- ABLOY® CLASSIC
- ABLOY® PROFILE
- ABLOY® EXEC
- ABLOY® DISKLOCK PRO
- ABLOY® PROTEC

Package includes

Cylinder, key deposit, and fitting nails.

When ordering, please specify

- Cylinder type
- Key deposit model

Application

ABLOY® key deposits are commonly used for storing route keys to apartment complexes, office buildings and factories.

Route keys can be of use to utility companies such as electricity, telephone, gas or cable TV companies as well as fire departments.

Route keys limit service people to access only those rooms where their equipment is installed. It also allows for the convenience of only having to carry one single key which can operate thousands of key deposits.

The ABLOY® key deposit cylinders allow each company to have their own unique key combination. The cylinder can be ordered keyed different, keyed alike or master keyed.

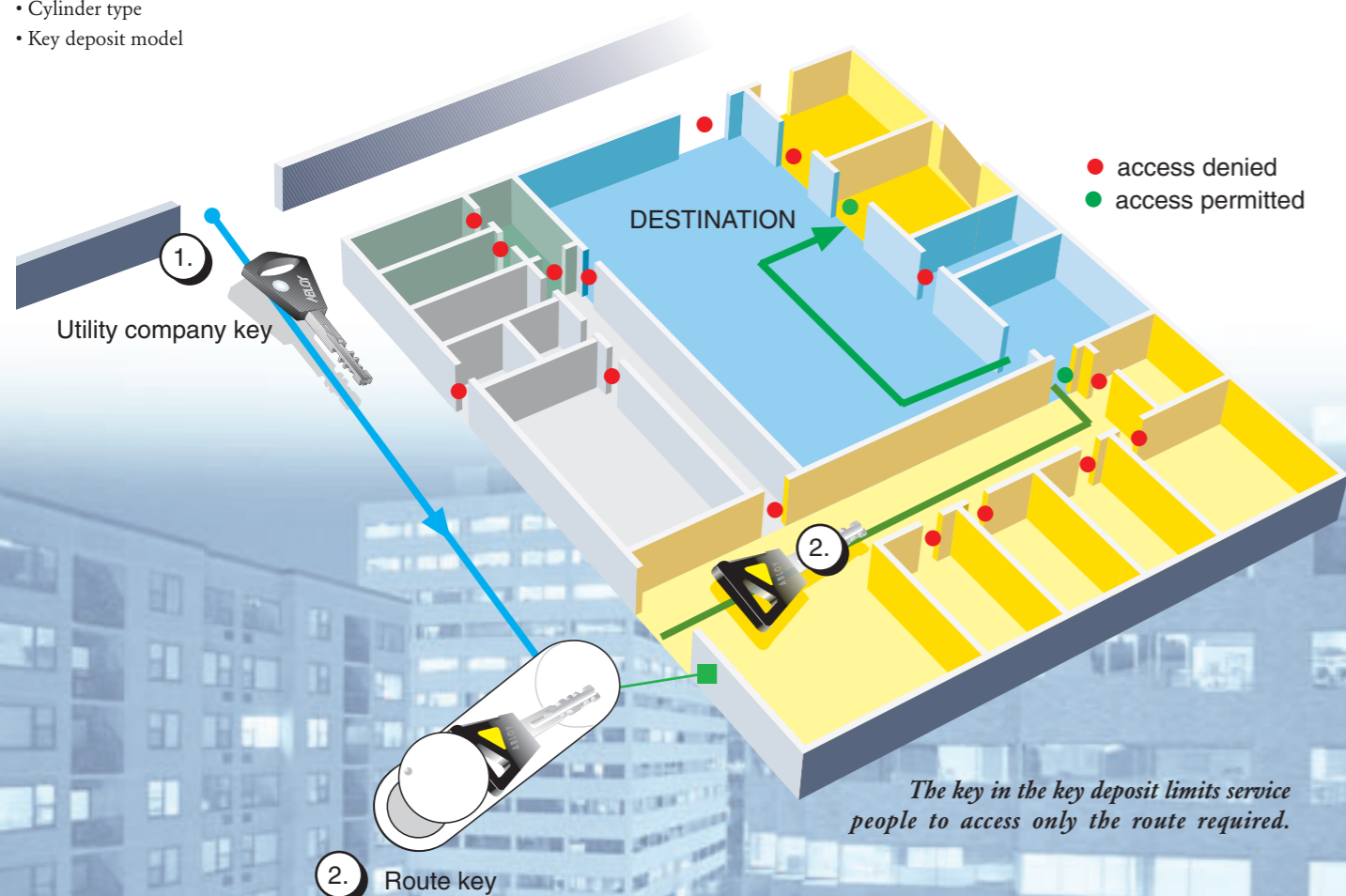

Models available

410459 key deposit

410460 key deposit with microswitch

410461 key deposit with collar and dust plate

410462 key deposit with collar, dust plate and microswitch

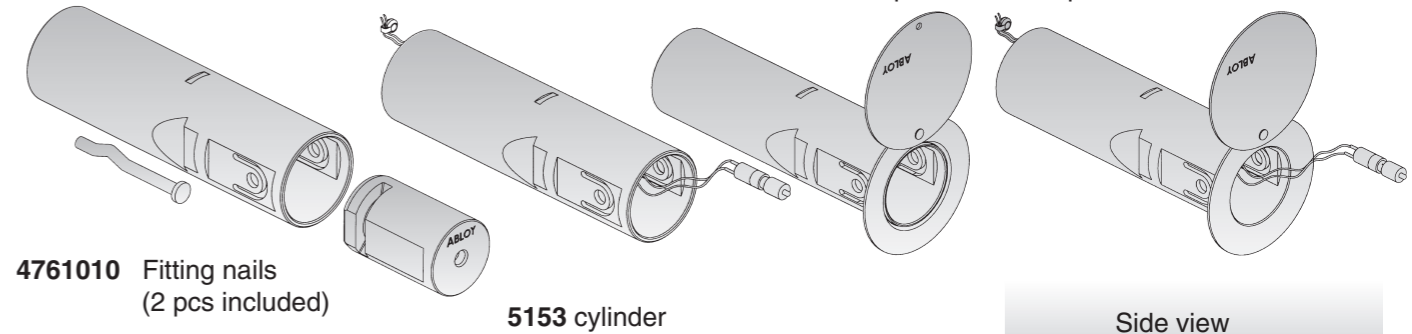

Installation

A recommendable installation height for a key deposit is more than 1,8 m, the back of the deposit a bit higher (about 4 degrees) than the front.

Drill a hole for the key deposit with a drill of Ø40 mm.

With help of a drill jig, drill counter sinkings for retainer lugs to the key deposit using a rock-drill of Ø10 mm (measure drilling depth from the drill jig level.)

Clean up the key deposit hole carefully. Bend the retainer lugs a little outwards. Spread glue mass on the surface of the deposit, push the key deposit into the hole, rubbing it at the same time, and bend the lugs with help of an installing tool.

Drill a deep hole, at least 55 mm, with a rock-drill of Ø5 mm, for nails and use holes in the retainer lugs for the key deposit as a drill jig (the length of the drill has to be at least 130 mm). Before you drill the second hole, drive the second nail loose into it.

Nail heads have to be left so deep that the cylinder housing goes well into the right place. Finally, clean the inner parts of the key deposit from all splashed masses and check the function of the cylinder housing.

For other installation alternatives please refer to the installation instructions delivered with the products.

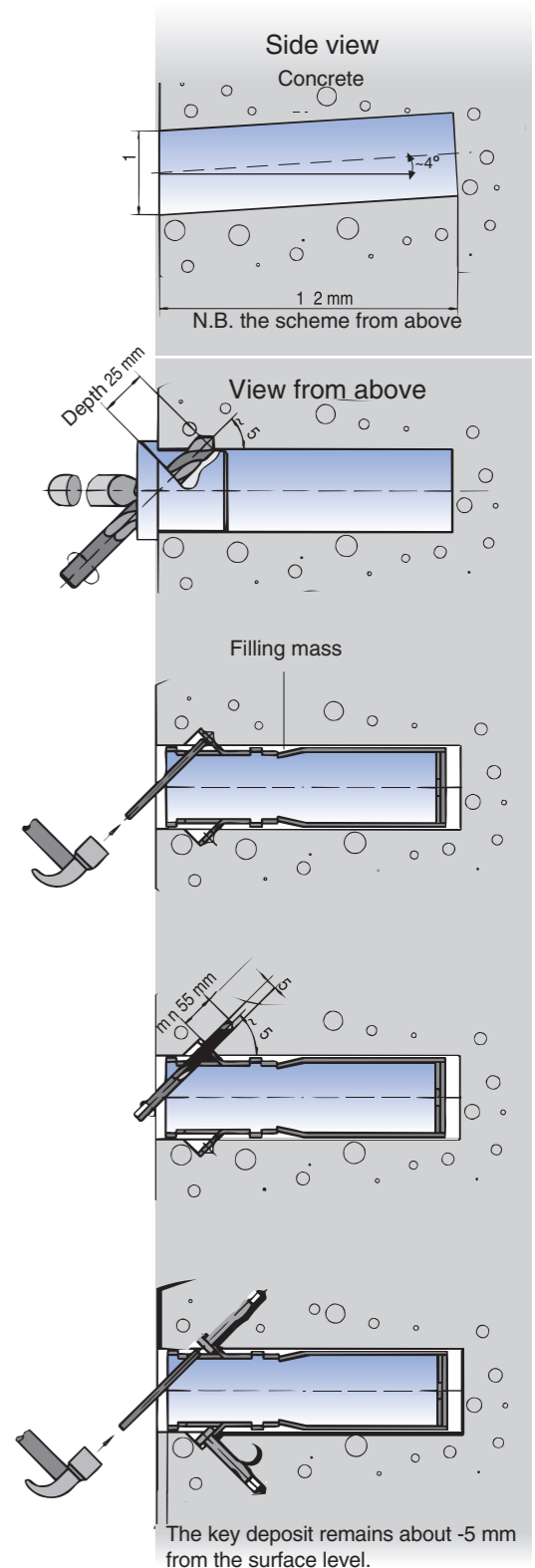

ABLOY® – the sign for security



The quality and environmental systems used by Abloy Oy guarantee that customers can be certain of **ABLOY®** quality in every field. We received our first Quality System Certificate - SFS-EN ISO 9001 - in 1989. Just eight years later, Abloy Oy was one of the first companies in Finland to be granted an SFS-EN-ISO 14001 Environmental System Certificate.

Our products are designed and manufactured not only to provide high levels of security, but also to be reliable, user-friendly and aesthetically pleasing. **ABLOY®** is your sign for security.



ABLOY® is a registered trademark of Abloy Oy, one of the leading manufacturers of locks, locking systems and architectural hardware and the world's leading developer of products in the field of electromechanical lock technology.

The unique **ABLOY®** detainer disc cylinder mechanism has several advantages over conventional locking mechanisms. Ever since its invention in 1907, it has been a symbol of high security and superior performance.

Our range consists of electromechanical locks, cam locks, padlocks, office furniture locks, rim locks, lock cases, cylinders for different types of mortice locks, door closers, door automatics and architectural hardware. **ABLOY®** locking solutions for every application are available from our world-wide network of distributors.

Customer-oriented development, combined with our long experience and extensive security expertise, mean that **ABLOY®** security solutions employ the very latest technology to meet your needs.



www.abloy.com

Abloy Oy
Wahlforsinkatu 20
P.O. Box 108
FI-80101 JOENSUU
FINLAND
Tel. +358 20 599 2501
Fax +358 20 599 2209

